

An Automatic Grain Dryer Prototype Using the PID Method as Temperature Controller

Akhmad Fahrudi¹, Ricky Rhamdany²

^{1,2} Electrical Engineering Departement, Institut Teknologi Adhi Tama Surabaya, Indonesia

¹ fahrudiakhmad@itats.ac.id, ² rickyramdany123@gmail.com

Abstract— The value of rice grain content after harvest is quite high, around 20-23% in the dry season, and around 24-27% in the wet season. It was drying grain after harvest was processed by the conventional or manual method that carried out the grain drying in the sun. This method has several disadvantages, such as the dependence on the weather, requires a large area, and 54 hours for drying so that the grain becomes dry with a moisture content of 14.12%. From this problem, the researchers made a grain drying machine that could work automatically. The drying machine is made to solve the issues of conventional grain drying so that the machine was completed with a K type thermocouple temperature sensor and grain moisture content. Whereas the heating media uses a fire that is fueled with LPG gas, and then the heat from the fire has flowed into the furnace or grain drying chamber. The heating arrangement was made by regulating of flowing LPG gas to the nozzle through the opened and closed variable valve where the valve shaft was connected to the DC motor shaft. The application of the PID method also used in this drying machine, which has a purpose while controlling the drying temperature to match the Set Value (SV) or the desired temperature at 38°C. The grain moisture content value is considered to have dried up when the grain moisture content value is 14%. The PID method that is implanted into the ATmega16 microcontroller will give a signal to the motor driver circuit to regulate the direction of rotation of the DC motor connected to the opened and closed valve variable. PID method testing was done by trial error and has produced a steady-state error of 5.2% at $S0056=38^{\circ}\text{C}$ with constant values $Kp=2$, $Ki=2$, and $Kd=10$. Whereas for drying grain testing on harvested is done by selecting Ciherang grain with a moisture content of 20% and a weight of 3 kg. The grain drying process takes 30 minutes so that the value of the water content becomes 14% with a drying temperature of 38°C, so the grain drying rate on this machine is 0.17% per minute.

Keywords— grain drying; PID method; thermocouple; grain water content; atmega16.

I. INTRODUCTION

Generally, the grain moisture content after harvest (postharvest) is quite high, around 20-23% in the dry season, and in the wet season around 24-27% [1]. The grain moisture content value is not safe to store because easily attacked by fungus and damages the grain quality so that the rice produced can be yellow or brownish yellow [2]. The postharvest grain drying process requires serious handling because it maintains grain quality during the storage process. Stored dry rice (GKS) has a standard moisture content of 14% to 18%, whereas if the grain be grounded, or dry unhusked rice (MPD) has a maximum moisture content standard of 14% [3]. Grain drying is done to reduce the amount of water content or water content in the grain.

Farmers process the postharvest grain drying using conventional methods by drying the grain within the sunlight. This method is very dependent on the heat of the sun as weather, but it also requires a large area and a long drying time. Previous researchers have reported that unhulled grain drying in conventional rice was found to be quite high, around 21.12% [4]. While drying time with hot weather is needed up to 54 hours so that the grain moisture content becomes 14.12% [5] During the rainy season, grain drying time can take longer and as a result, the grain will be piled up and can cause the grain to rot and grow seeds.

From these various problems, the use of an artificial dryer is very necessary to dry the grain. Artificial drying machine that has developed has several types such as box type, circulation, fluidization, oven. Dryer-made drying machines

have a lower risk of losing grain quality compared to drying [6]. Following technological advances in the field of automation, researchers have developed grain dryers, especially in terms of instruments and controls. One example is research on grain drying machines in which microcontrollers and sensors are implanted [7]. The grain drying machine in the study was equipped with temperature and humidity sensors and blowers as the heating source, but the results obtained from the study said that the grain drying time was not much different from conventional drying. Subsequent research has also made a grain dryer with temperature control from which the heating source comes from the heater. Heating media that uses a heater will result in absorbing large electrical power if the machine is applied to a large scale [8].

From the reasons above, researchers have made a grain dryer prototype machine that has a grain capacity for a maximum of 5kg. This drying machine is also equipped with a K type thermocouple temperature sensor and grain moisture sensor. Thermocouple sensors are used to monitor the temperature of the heater to match the desired temperature of 38°C. The media or heating source in this drying machine comes from the heat of a fire fueled by LPG gas, with the aim that it does not require or consume large power. In order to evenly heat the grain, this machine is equipped with a stirrer (blade) in the furnace whose driving source is from a 1 phase AC motor. Drying temperature control using the PID method is done by adjusting the valve opening and opening variables of LPG gas lines to the nozzle.

Based on the problems, the formulation of the problem in this research is how to design a grain drying machine with a heating source from LPG gas and apply the PID method in controlling the dryer temperature value and can monitor grain water content in real-time.

The purpose of this observation is to make an automatic drying machine with a heating source from LPG gas, and the drying temperature can be maintained at 38°C with a maximum error value of 10%. In addition, the measurement of grain moisture content is carried out in real-time.

The scope of this research is the maximum weight of grain in the dryer is 5kg, the number of thermocouple sensors and grain water content each one, and the maximum drying temperature is only up to 40°C.

II. RESEARCH METHODOLOGY

The study was conducted by focusing on the stability of the drying temperature and measuring grain moisture content. The number of sensors on this machine is two, namely one thermocouple sensor and one water content sensor. The desired drying temperature value can be entered via the push button. Following is a block diagram of a grain drying machine system shown in Figure 1.

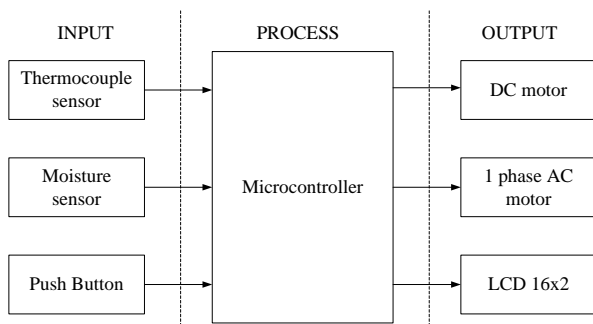

Figure 1. Blok diagram system

Thermocouple sensors and grain moisture content are placed inside the grain heating furnace. Data from the two sensors will be processed by the Atmega16 microcontroller, which is then used to control the heating temperature through a DC motor. One phase AC motor is used to turn the blade so that grain drying can be more evenly distributed. If the grain moisture content has reached 14%, the machine will automatically stop, namely, with a microcontroller giving a signal to stop the heating process and the AC motor.

A. Temperature Sensor

The temperature sensor used in the grain dryer is a K type thermocouple sensor. This sensor emits a voltage with a sensitivity of 40µV/°C. So that the output voltage can be read by the internal ADC Atmega16, a non-inverting type amplifier circuit is needed, which uses an AD620 type op-amp IC.

The non-inverting gain (G) in Figure 2 is designed 250 times so that the 40µV/°C thermocouple sensitivity will be changed to 10mV/°C. The value of GE can be searched based on Equation (1).

$$R_G = \frac{49,4K\Omega}{G - 1} \dots\dots\dots(1)$$

$$= \frac{49,4K\Omega}{100 - 1} = 198,3\Omega$$

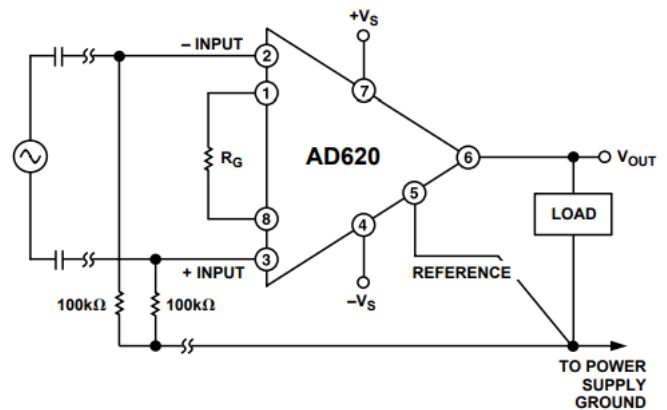
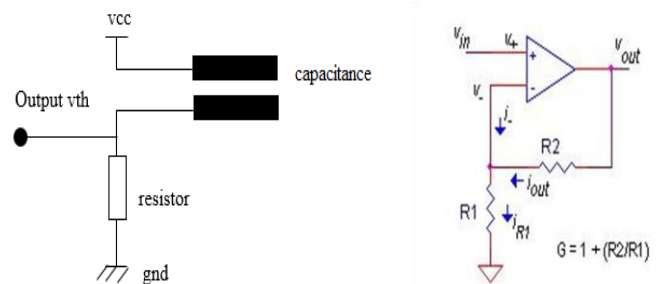

Figure 2. Thermocouple gain circuit

B. Moisture Sensor

This sensor is used to measure grain moisture content. The sensor is designed using two copper plate plates (from a plain PCB), which uses the principle of the capacitor. The size of the copper plate that is designed has dimensions of 3 x 2 cm with a distance between the plates is 1 cm. So that the capacitive sensor output becomes voltage, the capacitive sensor is connected in series with a resistor, as shown in Figure 3(a). Because the analog output voltage (V_{th} output) of the capacitive sensor is too small that it cannot be read by the ADC microcontroller, a non-inverting type amplifier circuit is needed, as shown in Figure 3(b).



(a) Design for moisture sensor (b) Non-inverting gain circuit
 Figure 3. The Moisture Sensor

C. LPG Gas Flow Control

The open and close valve in the LPG gas pipeline is used to regulate LPG gas flow to the nozzle, which can then increase and decrease the heating temperature of the grain dryer. As shown in Figure 4, the mechanical arrangement of grain drying is arranged by means of a variable valve shaft coupled with a DC motor shaft, which is also provided with an encoder disc so that it can determine what percentage of the valve cap open and close the pipeline.

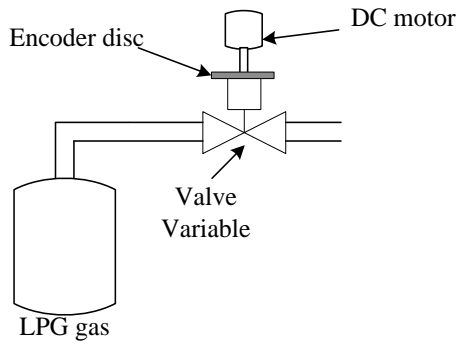

Figure 4. DC Motor Installation into gas valve LPG

D. PID Control System

The use of the PID method in controlling or stabilizing the heater in the grain dryer is by controlling the direction of the DC motor, which is coupled to the LPG gas variable valve. Following is the control system block diagram shown in Figure 5.

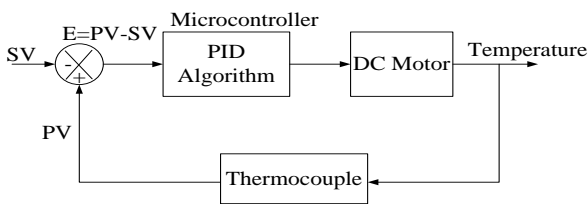

Figure 5. Controlling system block diagram

SV (Set Value) is the desired heating temperature value where the value can be changed via the push button, as shown in Figure 1. The PV (Present Value) is the actual temperature reading. The difference between PV and SV or error (E) will be processed into the PID algorithm, the results of which will be used to control the direction of rotation of the DC motor. PID control is basically a combination or a sum of three parameters, namely P (Proportional) control, I (Integral) control, and D (Derivative) control. The PID algorithm is a mathematical equation in a continuous form. So that the Equation (2) can be implanted into a microcontroller, it must be changed to discrete, as shown in Equation (2) [8].

$$R_n - R_{n-1} = K_p \cdot (e_n - e_{n-1}) + K_i \cdot \frac{e_n - e_{n-1}}{2} + K_D (e_n - 2e_{n-1} + e_{n-2}) \dots \dots \dots (2)$$

Where:

- R_n : PID output at t
- R_{n-1} : PID output before $t-1$
- e_n : Error at t
- e_{n-1} : Error at $t-1$
- e_{n-2} : Error at $t-2$
- K_p : Proportional constant
- K_i : Integral constant
- K_D : Derivative constant

E. Drying machine flowchart

The workings of the automatic dryer will be made as shown in Figure 6.

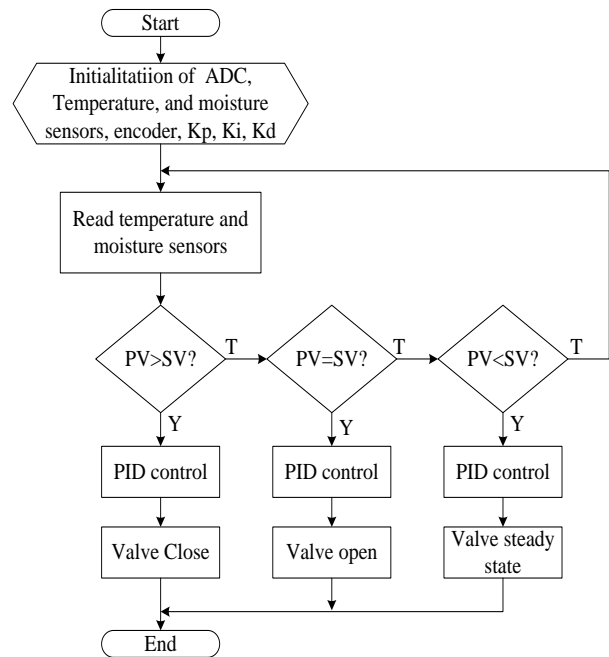

Figure 6. Drying machine flowchart

III. RESULT AND DISCUSSION

Grain drying machine is made using a framework and material made of iron and stainless and has a maximum capacity of 5kg of grain. Figure 7 shows the mechanical shape and laying of an electronic panel and a heating source that is placed under a grain drying furnace.

Installation and arrangement of the heater that has been made looks like in Figure 8, where the shaft of a DC motor which is already equipped with a rotary encoder connected to the shaft of a variable valve or often called a regulator. As for the installation of the thermocouple and moisture sensor, content is placed in a heating furnace and direct contact with grain. It is intended that the sensor can directly measure the parameters of the grain.

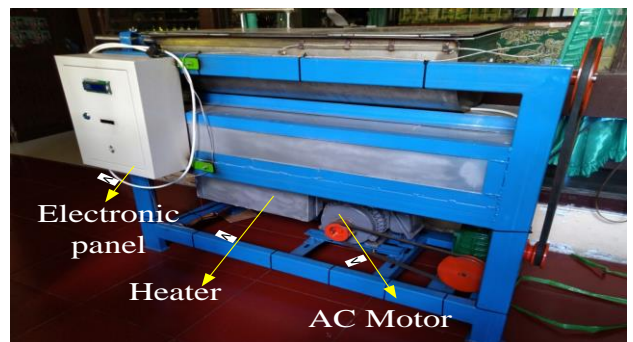

Figure 7. Mechanical of grain drying machine

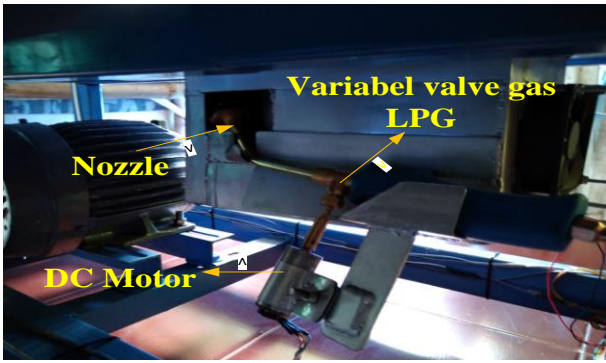

Figure 8. Heater System with LPG Gas

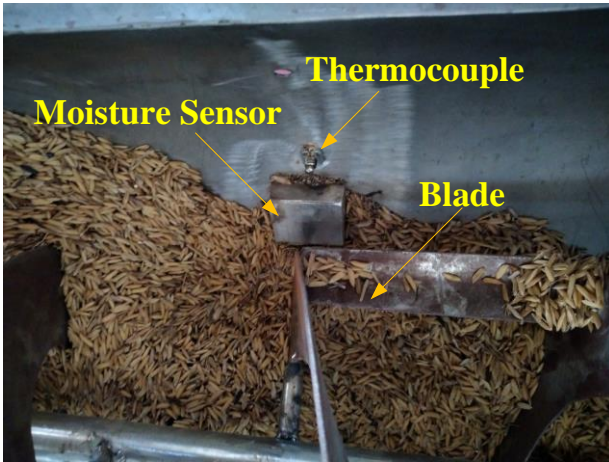

Figure 9. Installation of the thermocouple sensor and moisture sensor

Analyze the results of the performance of the grain dryer machine, each component was tested, and the entire test is carried out. Here are some test results:

A. Testing of Temperature Sensor

Thermocouple sensor testing is done by placing or placing the sensor in a grain heating furnace (as shown in Figure 9) then the temperature inside the furnace is increased by increasing the LPG gas flow. The temperature sensor reading error, the sensor is compared with a digital thermometer. Here is a graph of the thermocouple sensor test results.

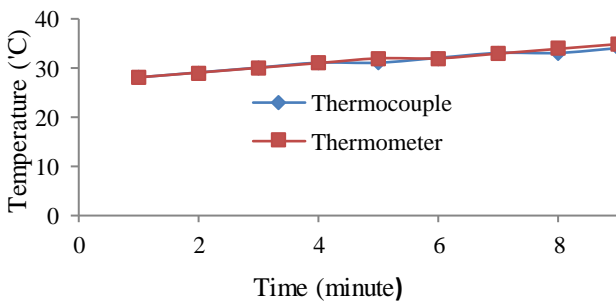

Figure 10. Graph of thermocouple sensor testing

In Figure 10, the thermocouple sensor is tested at 28-35°C with the required time up to 10 minutes. The average difference between the thermocouple sensor that is read by the microcontroller with a digital thermometer is 1°C, with an error of 3.1%.

B. Testing of Grain Moisture Sensor

The error value of grain moisture sensor readings, this test is done by comparing it with the digital Grain Moisture Meter, as shown in Figure 11. The object used in this test uses grain, which is then given water gradually to increase the water content value.



Figure 11. Moisture Measurement with the instrument

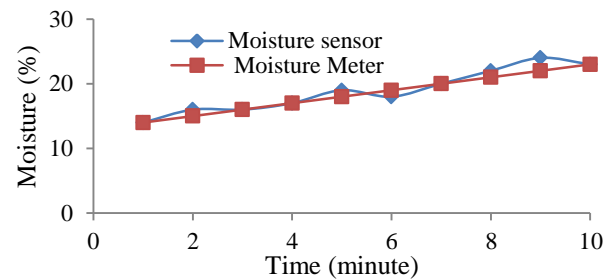

Figure 12. Graph of tested for moisture sensor to grain

The results obtained from the results of this test (Figure 12) that the biggest error in reading the grain moisture sensor is 8.3% when measuring 24% RH. This is due to precision when testing measurements.

C. Testing of Open Close Variable Valve

The test aims to find out how many degrees or percent of the valve from the LPG gas flow regulation to the nozzle has been opened via a DC motor. The first test in this section is to measure the degree of rotation of the DC motor shaft, which is adjusted to the arc, as shown in Figure 13(a). After that, the test is continued by connecting the DC motor shaft with the shaft of the LPG gas valve, and the number of rotary encoder

holes detected by the microcontroller will be displayed on the LCD in Figure 13(b). From the results of tests carried out, to open the valve 100%, it takes three turns with the number of 360 changes (Table I). Here are the results of the test opening and closing of the valve variable.

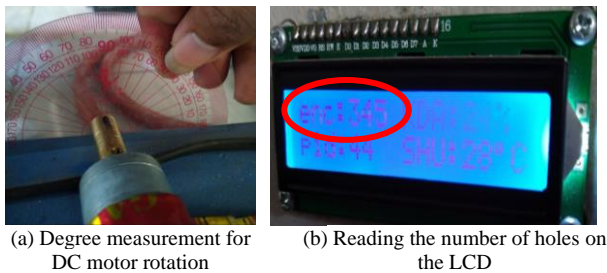

Figure 13. The Testing of Open Close Variable Valve

TABEL I
TESTED RESULTS OF THE ENCODER HOLES

Testing	Valve Open (%)	Number of Encoder Holes
1	100	360
2	90	324
3	80	288
4	70	252
5	60	216
6	50	180
7	40	144
8	30	108
9	20	72
10	10	36

D. Testing of the PID Metode

One of the factors that influence the results of the PID control system is the constant values of K_p , K_i , and K_d . Therefore, to get optimal results, and the corresponding constant values, the temperature control test using the PID method was carried out by several trial error tests by taking the SV value of 38°C. The following are the results of responses from several PID control system tests.

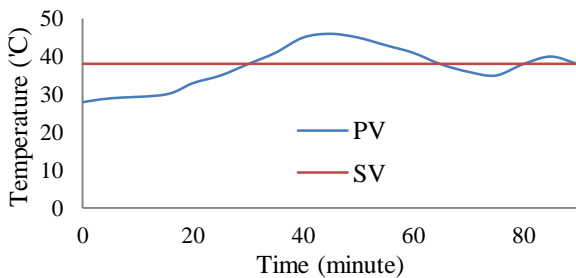

Figure 14. First tested with $K_p=3$, $K_i=1$, $K_d=6$

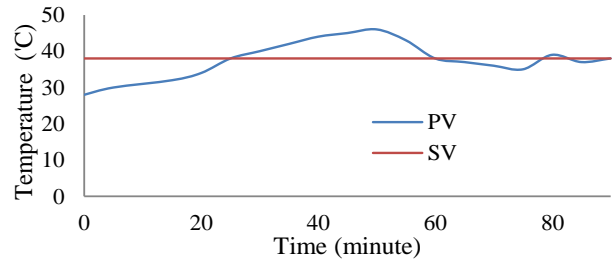

Figure 15. Second tested with $K_p=3$, $K_i=1$, $K_d=6$

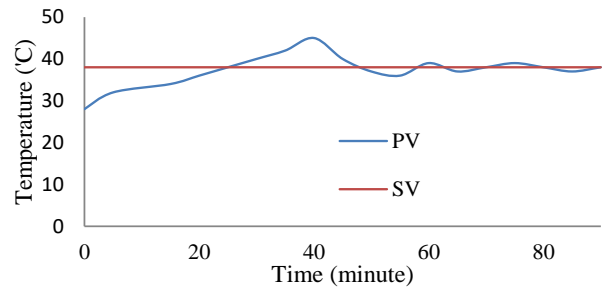

Figure 16. Third tested with $K_p=2$, $K_i=2$, $K_d=10$

TABLE II
RESPONSIVE TESTED PID CONTROL FROM ANY TESTED

Testing	rise time (minute)	Overshoot (%)	Error steady-state (%)
1	30	21,1	13,2
2	25	21,1	5,2
3	25	18,4	5,2

From the three PID control response test results in Table II, as shown in Figures 14, 15, and 16, the time required for the temperature reading by the thermocouple (PV) to reach SV or rise time ranges from 25-30 minutes. This is influenced by the fire factor that is less large, and the regulation of the flow or propagation of the heating source from the nozzle to the drying furnace is not good.

E. Overall Testing

The results of the performance of the grain dryer can be known by doing the whole test. Testing is done by combining all components such as temperature sensors, grain moisture content, PID method, and automatic system if the grain is deemed dry. The value of the PID constant used in this test is referring to the results of the PID table 2 test method, namely $K_p=2$, $K_d=2$, and $K_i=10$. In this test, the type of grain used is the type of grain Ciherang with a moisture content of 20% and a weight of 3 kg.

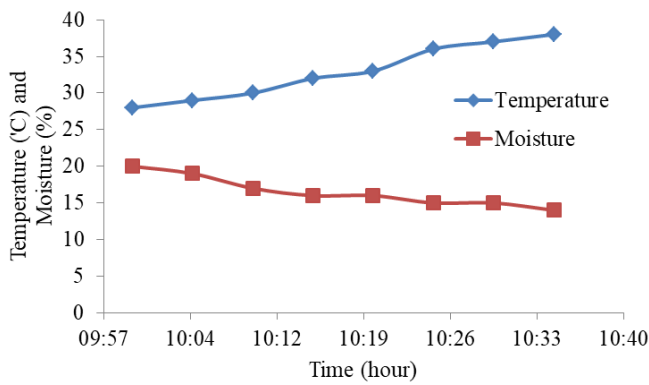

Figure17. Graph of Temperature rate and grain moisture

In Figure 17, it can be seen that the grain drying of the grain water content decreases by 6% (from 20% to 14%). It takes 30 minutes so that the grain water content rate in this machine is 0.17% RH/minute. The drying machine can stop automatically if the grain moisture content has reached 14%. To see the comparison between drying by machine and conventional methods, a grain drying test with the grain is dried in the sun. Here are the results of the test.

TABEL III
 RESULTS OF DRUG DRYING TEST WITH CONVENTIONAL WAYS

Time	Temperatur (°C)	Moisture (%)
10:00	30	20
11:00	32	20
12:00	35	18
13:00	35	17
14:00	36	17
15:00	33	16
16:00	30	14

The conventional drying test, as shown in Table III, starts at 10.00 with the grain moisture content before being dried in the sun by 20%. The time required for the grain to dry with a moisture content of 14% is 6 hours. From the two test comparisons, it was found that the drying time with the machine was 12 times faster compared to conventional drying.

IV. CONCLUSION

Grain drying machines that have been made that use LPG gas fuel can raise temperatures up to 46°C. Implementation of the PID method in controlling the temperature on the grain dryer takes 25 to raise the temperature from 28°C to the desired temperature (SV), which is 38°C. While the value of the steady-state temperature error of 2.5%. Incorrect setting of the flow or propagation of the heater from the LPG gas fire to the heating furnace is incorrect.one major cause for the rise in temperature takes 25 minutes. Grain drying for one process takes 30 minutes so that the grain moisture content in this machine is 0.17% per minute. Whereas for drying using the conventional method takes 6 hours, so that the drying of grain using this machine with a drying temperature of 38°C has time 12 times faster than drying with the conventional method. In addition, this machine can stop automatically when the grain

is dry. This is because it is equipped with a grain moisture sensor that monitors in real-time.

ACKNOWLEDGMENT

Researchers would like to thank friends in the ITATS electrical department who have provided input as well as ITATS electrical engineering students who have helped in the manufacture of this dryer.

REFERENCE

- [1] Purwadaria, H.K., "Problems and Priorities of Grain Drying in Indonesia, in: Grain Drying in Asia. Proceedings of an International Conference held at the 74 FAO Regional Office for Asia and the Pacific", Bangkok, Thailand, ACIAR Proceedings No. 71 (1995). pp. 201–209, 1995.
- [2] Nugraha, S., Thahir, R., Sudaryono, "Keragaan Kehilangan Hasil Pascapanen padi pada 3 agroekosistem". Buletin Teknologi Pascapanen Pertanian. Vol 3. p: 42 – 49, 2007
- [3] Napitu, Y. O, "Desain Model Pengereng Spouted Bed Dua Dimensi untuk Pengerengan Gabah"(Tesis). Institut Pertanian Bogor, Bogor, 2016
- [4] Iswari, K, Survei Mutu Beras di Sumatera Barat. "Kerja Sama Balai Pengkajian Teknologi Pertanian Sumatera Barat dengan Dinas Sosial Provinsi Sumatera Barat", 2011
- [5] Wongpornchai, S., Dumri, K., Jongkaewattana, S., Siri B, "Effects Of Drying Methods And Storage Time On The Aroma And Milling Quality Of Rice (Oryza Sativa L)". Journal of Food Chemistry. Vol 87(3). p:407-414, 2003
- [6] Nugraha, S., Thahir, R., Sudaryono. 2007. "Keragaan Kehilangan Hasil Pascapanen padi pada 3 agroekosistem". Buletin Teknologi Pascapanen Pertanian. Vol 3. p: 42 – 49.
- [7] Teguh Hidayat, "Rancang Bangun Prototype Penngeringan Padi Otomatis Berbasis Mikrokontroler AT89S52". Seminar Nasional TEKNOKA_FT UHAMKA, 30 Januari 2016.
- [8] Akhmad Fahrudi.,Andy Suryowinoto, "Implementasi Kontrol PID Pada Mesin Penetas Telur Burung Murai". Jurnal Ilmiah Bidang Teknologi Informasi dan Komunikasi Vol. 4 No. 1, Januari 2019.
- [9] Ebiet Van Heriyanto, Harianto, Pauladie Susanto. "Rancang Bangun Alat Pengereng Gabah dengan Pengendali suhu dan kelembaban Ruang Berbasis Arduino Uno R3," JCONES Vol.3, No 1(2014) 120-125.