

The Role of Competence, Work Discipline and Work Environment Improving Employee Performance in Cooperatives in Jember Regency

Nurul Qomariah^{1*}

(nurulqomariah@unmuhjember.ac.id)

Faculty of Economics and Business Universitas Muhammadiyah Jember

Nuriesty Putri Utamy²

(hnuries@gmail.com)

Faculty of Economics and Business Universitas Muhammadiyah Jember

ABSTRACT

Cooperatives are one of the privately owned enterprises that also participate in driving the national economy. This research was conducted at cooperatives throughout Jember Regency and had the aim of being the first to test and find out the effect of the work environment (X) on work discipline. The second goal is to test and find out the effect of work discipline (Z) on employee performance, and the last goal is to test and find out the effect of the work environment (X) on employee performance (Y). The population of this research is all employees of cooperatives operating in Jember Regency, totaling 1488 employees. The sample size was determined using the Slovin formula and the sample size was 315 respondents. The sampling technique is to use probability sampling with the technique taken, namely proportional sampling for each active cooperative. Data analysis used included: descriptive analysis, analysis of validity and reliability tests, and analysis of hypotheses, all of which were processed using Partial Least Square (SEM-PLS) with the Warp PLS 6.0 program. After being analyzed using Warp PLS, the findings of this study are that competence has an impact on employee performance. Meanwhile, work discipline has an impact on employee performance at cooperatives in Jember Regency. The work environment has an impact on employee performance. Thus, the first hypothesis is accepted. The second hypothesis is accepted while the third hypothesis is accepted.

Keywords: Cooperative; Employee Performance; Work Discipline; Work Environment

1. INTRODUCTION

Cooperatives are business entities that have members, where each member has their own duties and responsibilities. In cooperatives, each member has voting rights in making decisions based on deliberation and consensus (Qomariah 2014). Based on Law Number 25 of 1992, cooperatives have the aim of making members prosperous in particular and society in general. Cooperatives also play a role in building a national economic order to create an advanced, just and prosperous society based on Pancasila and the 1945 Constitution. The cooperative principle emphasizes that cooperatives must have independence in order to be able to compete with other business entities. Therefore, the advancement of cooperatives can give impetus to improve the standard of living of members and the surrounding community.

The current development of the number of cooperatives in Indonesia has reached 127,846 units in 2021. This number has increased by 0.56% compared to the previous year (year-on-year/yoy). The largest number of cooperatives in Indonesia in 2021 will be in East Java, namely 22,845 units or around 17.86% of the total cooperatives. Then followed by West Java and Central Java with 15,621 units and 10,270 units respectively.

(<https://databoks.katadata.co.id/datapublish/2022/12/06/jumlah-koperasi-di-indonesia-kembali-meningkat-semenjak-pandemi> 2022). Seeing the development of more and more cooperatives, cooperatives must continue to improve organizational performance. Organizational performance can increase with a record that employee performance must also increase.

Performance is the result of work achieved by an employee who has duties and responsibilities in accordance with those given to him (A. A. P. Mangkunegara 2018). Fahmi

(2014) says that performance can be interpreted as the result of a process that refers to and is measured over a certain period. Performance can also be interpreted as the result of the work of an employee, a management process or an organization as a whole, where the work results must be shown concretely and can be measured (Azhad, Anwar, and Qomariah 2015). Employee performance can increase because of the competence possessed by employees, work discipline and also the work environment.

In carrying out duties in an organization, every employee must have basic abilities. Every employee must have basic abilities in order to be able to face all the challenges and rapid and dynamic changes that occur at any time. According to (Qomariah 2020), competency is the skills, abilities and authority that a person has as a provision in carrying out all organizational tasks. The more skilled a person is in a job, it indicates that the employee's skills/competence are better. Research (Mustikawati and Qomariah 2020), (Ataunur and Ariyanto 2015), (Rande 2016), (Setiawati 2017) states that competence has a positive impact on employee performance. Several other studies, namely those conducted by ((Friolina et al. 2017), (Basalamah 2017), (Adam and Kamase 2019), (Amdani et al. 2019) also showed that employee competency influences employee performance. Research (Setiawati 2017), (Manik and Syafrina 2018) (Wasiman 2020), (Pinca 2015) states that increased performance is due to the competencies possessed by employees. Research conducted by (Qomariah et al. 2023), (Rusmayanti, Martini, and Qomariah 2022), (Setiawan and Qomariah 2022), (Nursaid et al. 2020), (Wahyudi, Qomariah, and Sanosra 2022), also states that Competence has an influence on employee performance.

The following factors can improve employee performance in an organization, namely the work discipline of employees. One indicator of the company's success can be seen from the level of employee discipline. Work discipline can be interpreted as a tool for organizations to communicate with employees so that employees have good behavior by obeying all company regulations (M. S. P. Hasibuan 2016). Employees who try to obey all the rules that exist in a company means that they have implemented good work discipline. Research by (Azis 2021), (Syahputra 2021), (Darmadi 2020) states that work discipline has an impact on employee performance. Research conducted by (Rosalina and Wati 2020), (Titisari, Susanto, and Permatasari 2021), (Safitri 2013), (Sanjaya 2021) results that discipline has an effect on employee performance. Meanwhile research (Ingsih, Yanuardan, and Suhana 2021), (Ekasari et al. 2022), (Saputri, Qomariah, and Herlambang 2020), (Mu'ah et al. 2023) also states that work discipline has a good impact on performance employee.

According to Sedarmayanti (2017), a place where a number of groups carry out activities in order to achieve company goals is called the work environment. If an employee can carry out their duties properly, it is said that they work in a good work environment. Some empirical evidence regarding the relationship between work environment and performance, among others, was carried out by (Adi et al. 2022), (Sukowidodo et al. 2022), (Wahyudi, Qomariah, and Sanosra 2022), (Qomariah et al. 2021), (Qomariah et al. 2020) stated that a comfortable work environment can improve employee performance. Other studies include: (Adha, Qomariah, and Hafidzi 2019), (Ermawaty and Nugraheni 2015), (Anggitaningsih and Handriyono 2019), (Sitinjak 2018), (Fachreza, Musnadi, and Majid 2014), (Ratnasari and Dewi 2014), (Pribadi 2018), (Wibowo, Musadieg, and Nurtjahjono 2014), (Aktarina 2015), (Dessy, Yunita, and Sinulingga 2018) also states that the work environment can affect employee performance. While research (Iskandar and Juhana 2014), (E. A. Hasibuan and Afrizal 2019), (Raffie, Azis, and Idris 2018), (Rahim, Syech, and Zahari 2017), (Parashakti, Fahlevi, and Ekhsan 2020), (AnisaTriastuti 2018), (Ilmi, Arifianto, and Qomariah 2023), (Pioh and Tawas 2016), (Lumentut and Dotulong 2015), (Prakoso, Astuti, and Ruhana 2014), (Muhsin and Arifa 2018), (Candana, Putra, and Wijaya 2020), (Ardianti, Qomariah, and Wibowo 2018), (Priyono, Qomariah, and Winahyu 2018), (Utomo, Qomariah, and Nursaid 2019), (Sugiyatmi, Minarsih, and Edward Gagah 2016) stated that the work environment has a positive impact on employee performance.

This research was conducted at cooperatives that carry out activities in Jember Regency. The development of the number of cooperatives operating in Jember Regency is presented in Table 1 below.

Table 1: Number of Cooperatives Operating in Jember Regency

Year	Number of Existing Cooperatives
2016	1799
2017	1811
2018	1826
2019	1843
2020	1992
2021	1913

Based on Table 1., it can be concluded that the number of cooperatives operating in Jember Regency has fluctuations (up and down) in the number of cooperatives carrying out economic activities. Therefore, researchers are interested in conducting research on cooperatives operating in Jember Regency. The fluctuating number of cooperatives also needs to be continuously guarded because business fields other than cooperatives will also be competitors for cooperatives so that cooperatives must also continue to be demanded to improve the performance of their employees. Therefore, based on empirical phenomena and also what happened to cooperatives operating in Jember Regency, the purpose of this study is the first to examine and determine the effect of competence on employee performance. The second research objective is to test and determine the effect of work discipline on employee performance. while the third research objective is to test and determine the effect of the work environment on employee performance. This research is novel in relation to the research object, with the population studied being the competencies possessed by cooperative employees in Jember Regency.

2. LITERATURE REVIEW

2.1 Employee Performance

Performance is the work result achieved by an employee who has duties and responsibilities in accordance with those given to him (A. A. P. Mangkunegara 2018). Fahmi (2014) said that performance can be interpreted as the result of a process that is referred to and measured over a certain period. Performance can also be interpreted as the result of the work of an employee, a management process or an organization as a whole, where the results of this work must be shown in concrete and measurable (Azhad, Anwar, and Qomariah 2015). Performance is the result of the work of an employee, a management process or an organization as a whole, where the results of this work must be shown in concrete and measurable evidence (compared to predetermined standards). According to (M. S. P. Hasibuan 2016), performance refers to the level of success in carrying out tasks and the ability to achieve predetermined goals. Performance is declared good and successful if the desired goals can be achieved well. Performance appraisal is an organizational process for assessing the performance of its employees. The general purpose of performance appraisals is to provide feedback to employees in an effort to improve their performance and increase organizational productivity, especially those related to employee policies such as promotion goals, salary increases, education and training. Currently, with the dynamic business environment, performance assessment is something that is very meaningful for organizations. Organizations are required to choose criteria subjectively and objectively. Objective performance criteria are performance evaluations against specific standards, while subjective measures are how well an employee works overall.

2.2 Employee Competency

In carrying out tasks in an organization, every employee must have basic abilities. Every employee must have basic abilities in order to be able to face all the challenges and rapid and dynamic changes that occur at any time. According to (Qomariah 2020), competency is the skills, abilities and authority that a person has as a provision in carrying out all organizational tasks. The more skilled a person is in a job, it indicates that the employee's skills/competence are better. According to (Wibowo 2012) competency can be defined as the ability to carry out work or tasks based on skills and knowledge and supported by work attitudes determined by the job. Competence shows certain knowledge, skills and attitudes of a profession in the characteristics of certain skills, which are the characteristics of a professional. According to Law No. 13 of 2003, competency is the work ability of each individual which includes aspects of knowledge, skills and work attitudes that are in accordance with established standards.

2.3 Work Discipline

One indicator of the company's success can be seen from the level of employee discipline. Work discipline can be interpreted as a tool for organizations to communicate with employees so that employees have good behavior by complying with all company regulations (Handoko 2015). Employees who try to obey all the rules that exist in a company means that they have implemented good work discipline. According to (Sedarmayanti 2017a), discipline is a person's willingness and willingness to understand and obey the regulatory norms that apply around him. According to (Nitisemito 2014), work discipline is an attitude, behavior and actions that are in accordance with the organization's regulations, both written and unwritten. According to (A. . A. P. Mangkunegara 2017), employee discipline is the characteristic of an employee who complies with the rules and regulations of a particular organization. Discipline greatly affects the performance of employees and the company. Discipline should be seen as a form of training for employees in carrying out company rules. The more discipline the higher the work productivity of employees and company performance.

2.4 Work Environment

According to Sedarmayanti (2017), a place where a number of groups carry out activities in order to achieve company goals is called a work environment. If an employee can carry out their duties well then it is said that they are working in a good work environment. According to (Afandi 2018), the work environment is something that exists in the workers' environment which can influence them in carrying out their duties, such as temperature, humidity, ventilation, lighting, noise, cleanliness of the workplace, and whether or not work equipment is adequate. The work environment can be interpreted as all the tools encountered, the surrounding environment where a worker is, his work methods, as an influence on his work both as an individual and as a group. The work environment is the entire work facilities and infrastructure around employees who are carrying out work which can influence the implementation of the work.

2.5 Hypothesis Development

The Effect of Competence on Employee Performance

To complete tasks in an organization, an employee must have certain skills and expertise. Skills and expertise must be possessed by an employee so that work in an organization can be completed in accordance with the objectives to be achieved. Therefore an employee must have competence in a particular area of expertise. Competent employees are usually always competent in completing a job given to them. Therefore the competence possessed by a person can improve a person's performance. Research (Simbolon 2017), (Kapahang, Kojo, and Uhing 2014), (Mulyani and Saputri 2019), (Novita and Yulianti 2020) states that an employee's competency can make a

significant contribution to improving performance. Other studies were conducted by: (Fajduani, Bahri, and Effendy 2021), (Permanasari, Setyaningrum, and Sundari 2014), (Abdi and Wahid 2017), (Herawati and Mahfudurnajamuddin 2018), (Pujiarti 2019), (Sholehatusya'diah 2017), (Achmad 2016) which states that competence has an impact on employee performance.

H1: Employee competence can provide a significant increase in employee performance.

Effect of Work Discipline on Employee Performance

Adherence to rules and regulations in an organization is one of the keys to a company's success in achieving the goals to be achieved in accordance with the vision and mission that have been set. Employees who are accustomed to complying with existing regulations are usually able to complete tasks properly and on time. Complying with these regulations is an indication of work discipline within a company. Thus it can be concluded that if the average employee working in an organization always obeys the rules set by the company, the company's performance will be achieved indirectly. Much research on work discipline has been carried out, including by: (Fathurahman and Ahman 2020), (Hutajulu, Sintani, and Meitiana 2020), (Sugiono and Vitaloka 2019), (Tilaar, Sendow, and Jorie 2017), (Arda 2017), (Manese, Adolfini, and Walangitan 2020), (Lumentut and Dotulong 2015), (Muhsin and Arifa 2018), (Jufrizen and Sitorus 2021), (Candana, Putra, and Wijaya 2020), (Liana and Irawati 2014) the results of which are that work discipline that is always well executed will provide a significant increase in performance. While research conducted by: (Baharuddin, Alhabsyi, and Utami 2013), (Putra, Suwendra, and Bagia 2016), (Nuriyah, Qomariah, and Setyowati 2022), (Bentar, Purbangkoro, and Prihartini 2017), (Feel, Herlambang, and Rozzaid 2018), (Herawati and Mahfudurnajamuddin 2018), (Makkira, Gunawan, and Munir 2016), (Suwondo and Sutanto 2015), (Lopes 2016), (Sumowo 2017), (Sya'roni, Herlambang, and Cahyono 2018) which states that work discipline can improve employee performance.

H2: Work discipline that is always well implemented will improve performance.

The Influence of the Work Environment on Employee Performance

The work environment is a place where workers or employees carry out company operational activities. There are 2 (two) kinds of work environment in an organization, namely physical and non-physical environment. The physical work environment includes good layout, lighting, coloring and layout of furniture within the company. while the non-physical work environment includes the relationship between employees and leaders, colleagues and also with subordinates. All environmental conditions, both physical and non-physical, will have a good impact if managed properly. This work environment is very influential on the success of the company in achieving the goals to be achieved. Research (Prakoso, Astuti, and Ruhana 2014), (Muhsin and Arifa 2018), (Candana, Putra, and Wijaya 2020), (Ardianti, Qomariah, and Wibowo 2018), (Priyono, Qomariah, and Winahyu 2018), (Utomo, Qomariah, and Nursaid 2019), (Sugiyatmi, Minarsih, and Edward Gagah 2016) stated that the work environment has a positive impact on employee performance.

H3: A comfortable work environment can improve employee performance.

2.6 Research Conceptual Framework

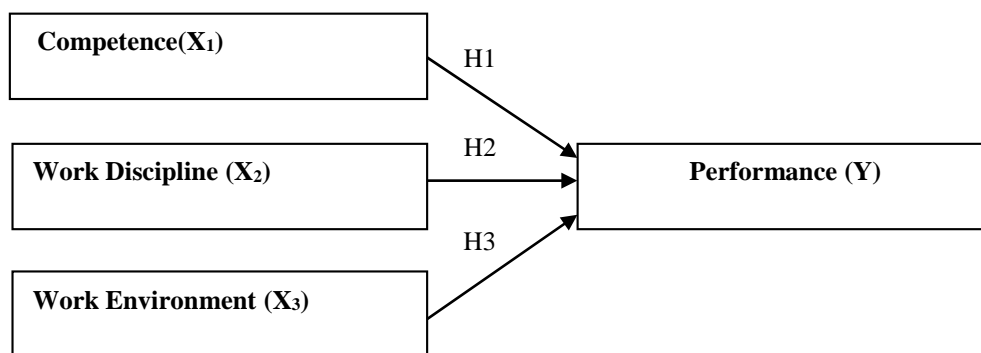

Figure 1: Conceptual Framework

3. RESEARCH METHODS

This research is a descriptive and verification research, where the research is a study that aims to examine the effect of the independent variable on the dependent variable (Sugiyono 2016). The population in this study were all employees of cooperatives operating in Jember Regency with a total of 1,488 employees. By using the Slovin formula, the sample size is 315 respondents. The sampling technique used in this research is probability sampling with the technique taken, namely proportional sampling. According to (Sugiyono 2017), the proportional sampling technique is a sample that is calculated based on comparison. This technique is used if the population has members or elements that are not homogeneous and proportionally stratified.

Employee competency is the ability and expertise that employees have in order to complete work within the company. The competency indicators used are as follows: 1) motive; 2) properties; 3) self-concept; 4) knowledge; 5) skills. Work discipline is the rules that apply in a company or organization which are obeyed by all individuals in the group. The indications of work discipline are: 1) corrective discipline; 2) preventive discipline; 3) progressive discipline. The work environment is a place where employees carry out activities in order to achieve company goals. The indicators used for the work environment variable are: 1) cleanliness of the work environment; 2) Information ; 3) Air Exchange; 4) Guarantee of Security; 5) layout. Performance is the result of the work of an employee for a certain period of time. The performance indicators are: 1) Quantity of work results; 2) Quality of work results; 3) Efficiency in carrying out tasks; 4) Obey the work rules; 5) Initiative; 6) thoroughness; 7) leadership; 8) honesty; 9) creativity. In data analysis using descriptive analysis, measuring instrument test analysis, research hypothesis test analysis. Meanwhile, to test the hypothesis, use Partial Least Square (SEM-PLS) with the WARP PLS 6.0 program. SEM-PLS. The measuring tool used was a research questionnaire which was distributed to 315 cooperative employees in Jember Regency with a questionnaire return rate of 100%, because all questionnaires were returned.

4. RESULTS AND DISCUSSION

4.1 Descriptive Analysis Results

The results of the descriptive analysis related to gender showed that of the 315 respondents, 56% or 175 respondents were male and 44% or 140 respondents were female. Based on calculations related to the age of the respondents, the result is that respondents aged between 20 - 30 years are 11% or as many as 34 people, respondents aged between 31 - 40 years are 43% or as many as 136 people, and respondents aged between 41 - 50 years by 37% or as many as 28 people and then respondents with ages between 51 - 60 years by 9% or as many as 28 people.

4.2 Results of Research Questionnaire Test Analysis

The measuring tool in this research is a research questionnaire which needs to be tested for validity and reliability. For the validity test, the average variance extracted (AVE) value is used, while for the reliability test the Cronbach's alpha value is used. The results of the construct validity test are presented in Table 2. After carrying out calculations, in Table 2 it can be seen that each value on the cross-loadings factor has reached a value above 0.7 with a p value below 0.001. Thus the convergent validity test criteria have been fulfilled. Reliability test to test the reliability of the measuring instruments used in a study. The results of the research reliability test are presented in Table 2. After carrying out calculations and analysis, the results of the reliability test show that all research variables and indicators are reliable because they have a Cronbach's alpha value above 0.6.

Table 2: Research Validity and Reliability Test Results

	AVE X1 value	AVE X2 value	AVE X3 value	AVE Y value	Value of Cronbach Alpha
Indicator X1.1	0,741	0,676	-0,185	-0,776	0,747
Indicator X1.2	0,732	0,167	0,035	-0,644	
Indicator X1.3	0,734	-1,064	0,512	0,523	
Indicator X1.4	0,771	-0,381	-0,005	0,747	
Indicator X1.5	0,736	0,614	-0,354	0,117	
Indicator X2.1	0,068	0,849	-0,527	0,279	0,975
Indicator X2.2	-0,070	0,712	-0,531	1,076	
Indicator X2.3	-0,619	0,787	0,558	-0,270	
Indicator X2.4	-0,216	0,743	0,874	-0,695	
Indicator X2.5	0,681	0,727	-0,089	-0,546	
Indicator X3.1	0,006	-0,09	0,736	0,522	0,797
Indicator X3.2	-0,304	0,254	0,831	0,107	
Indicator X3.3	0,312	0,205	0,796	-0,595	
Indicator Y1.1	-0,310	-0,532	-0,088	0,718	0,861
Indicator Y1.2	0,110	0,071	-0,533	0,707	
Indicator Y1.3	0,241	0,415	0,418	0,773	
Indicator Y1.4	0,212	0,171	0,046	0,775	
Indicator Y1.5	-0,191	-0,980	-0,103	0,699	
Indicator Y1.6	0,122	-0,073	-0,217	0,752	
Indicator Y1.7	-0,033	0,231	0,051	0,745	
Indicator Y1.8	0,142	0,155	0,362	0,743	
Indicator Y1.9	-0,440	0,525	-0,028	0,772	

Source: data processed by researchers (2022).

4.3 Results of Hypothesis Test Analysis

Hypothesis testing was carried out to determine the impact of the independent variables (competence, work discipline and work environment) on the dependent variable (employee performance) in cooperatives that carry out operational activities in Jember Regency. The results of the hypothesis test analysis are presented in Table 3 below.

Table 3: Research Hypothesis Test Results

No	Relations Between Variables	Value of Path coefficients	Results of p-values	Results
1.	Competence → Employee Performance	0,342	Less than 0,001	H1 Accepted
2.	Work Discipline → Employee Performance	0,285	Less than 0,001	H2 Accepted
3.	Work Environment → Employee Performance	0,371	Less than 0,001	H3 Accepted

Source: data processed by researchers (2022).

4.4 Discussion

The Effect of Competence on Employee Performance

The results of the analysis show that the coefficient value of the competency variable is 0.342 with a p value of less than 0.001. Thus it can be concluded that the hypothesis which states that performance can increase because competence is acceptable (H1 is accepted) and H0 is rejected. So it can be concluded that competence has an impact on employee performance. To complete tasks in an organization, an employee must have certain skills and expertise. Skills and expertise must be possessed by an employee so that work in an organization can be completed in accordance with the objectives to be achieved. This research is in line with research conducted by (Herawati and Mahfudnurnajamuddin 2018), (Pujiarti 2019), (Sholehatusya'diah 2017), (Achmad 2016) which states that competence has an impact on employee performance. Meanwhile, research from ((Chandra, G, and Qomariah 2020) does not support this research because the result is that competence has no impact on employee performance.

The Effect of Work Discipline on Employee Performance

The results of the analysis show that the coefficient value of the discipline variable is 0.285 with a p value of less than 0.001. Thus it can be concluded that the hypothesis which states that work discipline has an impact on employee performance is acceptable (H2 is accepted) and H0 is rejected. So it can be concluded that the work discipline possessed by employees can have an impact on employee performance. Adherence to rules and regulations in an organization is one of the keys to a company's success in achieving the goals to be achieved in accordance with the vision and mission that have been set. Employees who are accustomed to complying with existing regulations are usually able to complete tasks properly and on time. Research that is in line with this research is that carried out by: (Makkira, Gunawan, and Munir 2016), (Suwondo and Sutanto 2015), (Lopes 2016), (Sumowo 2017), (Sya'roni, Herlambang, and Cahyono 2018) who states that work discipline can improve employee performance.

The Influence of the Work Environment on Employee Performance

The results of the analysis show that the coefficient value of the work environment variable is 0.371 with a p value of less than 0.001. Thus it can be concluded that the hypothesis which states that a comfortable and clean work environment and a beautiful environment can improve employee

performance is acceptable (H3 is accepted) and H0 is rejected. So it can be concluded that the comfortable work environment provided to employees can have an impact on employee performance. This research is in line with research conducted by (Prakoso, Astuti, and Ruhana 2014), (Muhsin and Arifa 2018), (Candana, Putra, and Wijaya 2020), (Ardianti, Qomariah, and Wibowo 2018), (Priyono, Qomariah, and Winahyu 2018), (Utomo, Qomariah, and Nursaid 2019), (Sugiyatmi, Minarsih, and Edward Gagah 2016) the result of which is that the work environment has a positive impact on employee performance.

5. CONCLUSIONS AND SUGGESTIONS

5.1 Conclusion

Based on the results of data processing that has been done, the conclusions in this study are as follows:

1. Competence possessed by employees can improve employee performance. Therefore, the cooperative in Jember Regency must continue to strive so that the cooperative's employees have competence according to the field of work in the cooperative.
2. Work discipline of employees can improve employee performance. Thus employees who always discipline the work in the company, their performance will increase.
3. The work environment can improve employee performance. Therefore, cooperatives must make the working environment as comfortable as possible, both physical and non-physical.
4. Thus, the general conclusion is that all the proposed research hypotheses are accepted. Employee competency, work discipline and environment variables have a positive impact on employee performance in cooperatives in Jember Regency.

5.2 Suggestions

All independent variables (competence, work discipline, and work environment) used in this study have a positive and significant impact on the dependent variable of employee performance), therefore cooperatives must continue to maintain and even improve what has been achieved so far. Future research can add variables outside the variables studied such as OCB and leadership.

6. REFERENCES

- Abdi, Nurgunawan, and Muhsin Wahid. 2017. "Pengaruh Kompetensi Dan Lingkungan Kerja Terhadap Kinerja Pegawai." *Jurnal Manajemen dan Bisnis Indonesia* 5(1): 48–61.
- Achmad, Suryana H. 2016. "THE EFFECT OF COMPETENCY, MOTIVATION, AND ORGANIZATIONAL CULTURE ON THE EMPLOYEE PERFORMANCE AT THE JAYAKARTA HOTEL, BANDUNG, INDONESIA." *JBHOST* 2(1): 136–46.
<http://doi.wiley.com/10.1002/ceas.12013%0Ahttps://www.researchgate.net/publication/317087330%0Ahttps://repositories.lib.utexas.edu/handle/2152/39127%0Ahttps://cris.brighton.ac.uk/ws/portalfiles/portal/4755978/Julius+Ojebode%27s+Thesis.pdf%0Auisir.salford.a>
- Adam, Fikri, and Jeny Kamase. 2019. "The Effect Competence and Motivation to Satisfaction and Performance." *International Journal of Scientific and Technology Research* 8(3): 132–40.
- Adha, Risky Nur, Nurul Qomariah, and Achmad Hasan Hafidzi. 2019. "Pengaruh Motivasi Kerja, Lingkungan Kerja, Budaya Kerja Terhadap Kinerja Karyawan Dinas Sosial Kabupaten Jember." *Jurnal Penelitian IPTEKS* 4(1): 47.
http://jurnal.unmuhjember.ac.id/index.php/PENELITIAN_IPTEKS/article/view/2109 (August 29, 2020).
- Adi, I Made et al. 2022. "Influence Of Empowerment, Work Environment and Work Attitude on The Performance of Emergency Room Nurses." *Quality - Access to Success* 23(187):

150–60.

- Afandi, Pandi. 2018. *Manajemen Sumber Daya Manusia (Teori, Konsep Dan Indikator)*. ed. Zanafa Publishing. Riau.
- Aktarina, Destia. 2015. “Pengaruh Karakteristik Individu, Pekerjaan Dan Lingkungan Kerja Terhadap Motivasi Dan Dampaknya Terhadap Kinerja Anggota Polri Di Polresta Palembang.” *Jurnal Media Wahana Ekonomika* 12(3): 42–54.
- Amdani, Dody, Sukaria Sinulingga, Yeni Absah, and Iskandar Muda. 2019. “The Effect of Competence and Organizational Culture on Employee Performance of Ganesha Medan Polytechnic.” *International Journal of Scientific and Technology Research* 8(4): 155–59.
- Anggitaningsih, Retna, and H. Handriyono. 2019. “Effect Of Environmental Work Leadership Style Compensation On Employee Productivity Intervening As Employee Satisfaction In Business Unit Pt. Brantas Bipraya In Jakarta.” *International Journal of Scientific and Technology Research* 8(7): 182–89.
- AnisaTriastuti, Dinie. 2018. “PENGARUH LINGKUNGAN KERJA, KOMPETENSI DAN IKLIM ORGANISASI TERHADAP KINERJA PEGAWAI.” *Journal of Management Review* 2(2).
<https://jurnal.unigal.ac.id/index.php/managementreview/article/view/1796/1472>.
- Arda, Mutia. 2017. “Pengaruh Kepuasan Kerja Dan Disiplin Kerja Terhadap Kinerja Karyawan Pada Bank Rakyat Indonesia Cabang Putri Hijau Medan.” *Jurnal Ilmiah Manajemen dan Bisnis* 18(1): 45–60.
- Ardianti, Febry Erfin, Nurul Qomariah, and Yohanes Gunawan Wibowo. 2018. “PENGARUH MOTIVASI KERJA, KOMPENSASI DAN LINGKUNGAN KERJA TERHADAP KEPUASAN KERJA KARYAWAN (Studi Kasus Pada PT. Sumber Alam Santoso Pratama Karangasari Banyuwangi) EFFECT.” *Jurnal Sains Manajemen & Bisnis Indonesia* 8(1): 13–31.
- Ataunur, Ilman, and Eny Ariyanto. 2015. “Pengaruh Kompetensi Dan Pelatihan Terhadap Kinerja Karyawan PT. Adaro Energy Tbk.” *Telaah Bisnis* 16(2): 135–50.
- Azhad, M Naely, Anwar, and Nurul Qomariah. 2015. *Manajemen Sumber Daya Manusia*. Jember: Cahaya Ilmu.
- Azis, Addi. 2021. “Pengaruh Disiplin Kerja Dan Motivasi Kerja Terhadap Kinerja Pegawai Pada Balai Perhutanan Sosial Dan Kemitraan Lingkungan Wilayah Sumatera.” *Jurnal Ilmiah Mahasiswa Ekonomi dan Bisnis [JIMEIS]* 2(1): 1–11.
<http://ejournal.stiemj.ac.id/index.php/ekobis/article/view/26/73>.
- Baharuddin, Aris, Taher Alhabsyi, and Hamidah Nayati Utami. 2013. “PENGARUH PELATIHAN, KOMPENSASI DAN DISIPLIN KERJA TERHADAP PRESTASI KERJA KARYAWAN (Studi Pada Kantor PT. PLN (Persero) Area Pelayanan Dan Jaringan Malang).” *Jurnal Profit* 6(2): 56–68.
- Basalamah, Muhammad Syafi. 2017. “The Influence Of Motivation, Competence And Individual Characteristics On Performance Clerk (The Study) In The City Of Makassar.” *International Journal of Scientific & Technology Research* 6(12): 148–53.
- Bentar, Aidin, Murdijanto Purbangkoro, and Dewi Prihartini. 2017. “ANALISIS PENGARUH KEPEMIMPINAN, MOTIVASI, DISIPLIN KERJA DAN LINGKUNGAN KERJA TERHADAP KINERJA KARYAWAN TAMAN BOTANI SUKORAMBI (TBS) JEMBER.” *Jurnal Manajemen dan Bisnis Indonesia* 3(1): 1–17.
- Candana, Dori Mitra, Ramdani Bayu Putra, and Ronni Andri Wijaya. 2020. “Pengaruh Motivasi Dan Lingkungan Kerja Terhadap Kinerja Karyawan Dengan Disiplin Kerja Sebagai Variabel Intervening Pada Pt Batang Hari Barisan.” *JEMSI, Jurnal Ekonomi Manajemen Sistem Informasi* 2(1, September).

<https://www.dinastirev.org/JEMSI/article/view/329/212>.

- Chandra, Januar Adie, Ni Nyoman Putu Martini G, and Nurul Qomariah. 2020. "Impact of Organizational Citizenship Behavior , Leadership , Individual Characteristics and Competence on Teacher Performance." *Jurnal Manajemen dan Bisnis Indonesia* 6(2): 244–56.
- Darmadi, Darmadi. 2020. "Pengaruh Lingkungan Kerja Dan Disiplin Kerja Terhadap Kinerja Karyawan Pada Indomaret Cabang Kelapa Dua Gading Serpong Kabupaten Tangerang." *JIMF (Jurnal Ilmiah Manajemen Forkamma)* 3(3): 240–47. <http://openjournal.unpam.ac.id/index.php/FRKM/article/view/5140/4070>.
- Dessy, Lidia Yunita, and Nora Anisa Br. Sinulingga. 2018. "Pengaruh Karakteristik Individu Dan Lingkungan Kerja Terhadap Kinerja Karyawan Pada PT. Perkebunan Nusantara II Pagar Merbau Dessy1,." *Journal of Management Science (JMAS)* 1(1): 1–6.
- Ekasari, Novita, Meirani Harsasi, Rini Yayuk Priyati, and Nurul Qomariah. 2022. "The Effect of Work from Home (WFH) and Work Discipline on Employee Performance Through Work-Life Balance (WLB) in the Covid-19 Pandemic : Explanatory Study at BPKAD Office , Bondowoso Regency." 5(12): 112–27.
- Ermawaty, Dinny Ardian, and Rini Nugraheni. 2015. "LINGKUNGAN KERJA NON FISIK TERHADAP KEPUASAN KERJA SERTA DAMPAKNYA TERHADAP KINERJA KARYAWAN (Studi Pada PT . PLN (Persero) Distribusi Jateng & DIY)." *DIPONEGORO JOURNAL OF MANAGEMENT* Volume 4(4): 1–11. <https://ejournal3.undip.ac.id/index.php/djom/article/view/13356>.
- Fachreza, Said Musnadi, and M. Shabri Abd Majid. 2014. "Pengaruh Motivasi Kerja, Lingkungan Kerja, Dan Budaya Organisasi Terhadap Kinerja Karyawan Dan Dampaknya Pada Kinerja Bank Aceh Syariah Di Kota Banda Aceh." *Jurnal Magister Manajemen* V(1): 42–56. <https://www.google.com/url?sa=t&rct=j&q=&esrc=s&source=web&cd=1&cad=rja&uact=8&ved=2ahUKEwiHnMrM7dvjAhWKpI8KHZ8FD2gQFjAAegQIAxAC&url=http%3A%2F%2Fjournal.umy.ac.id%2Findex.php%2Fbti%2Farticle%2Fdownload%2F2451%2F2431&usg=AOvVaw2eWz9IL0SzcSKDquKhp8z>.
- Fahmi, Irham. 2014. *Manajemen Kepemimpinan: Teori & Aplikasi*. Bandung: Alfabeta.
- Fajduani, Abdul Khalik, Syaiful Bahri, and Sjahril Effendy. 2021. "Pengaruh Kompetensi, Profesionalisme Dan Kinerja Dosen Terhadap Semangat Belajar Mahasiswa Fakultas Sosial Sains Universitas Pembangunan Panca Budi Medan." *Jurnal Bahana Manajemen Pendidikan* 10(2): 95. http://ejournal.unp.ac.id/index.php/bahana/article/view/115376/pdf_1.
- Fathurahman, Fikri Muhammad, and Eeng Ahman. 2020. "Pengaruh Pelatihan Sdm Dan Budaya Organisasi Terhadap Kinerja Karyawan Dengan Disiplin Kerja Sebagai Variabel Intervening Pada Attarakha Photography Bandung." *Eksis: Jurnal Riset Ekonomi dan Bisnis* 2(1, September). <https://dinastirev.org/JEMSI/article/view/324/201>.
- Feel, Nico H, Tony Herlambang, and Yusron Rozzaid. 2018. "Pengaruh Disiplin Kerja, Budaya Organisasi Dan Lingkungan Kerja Terhadap Kinerja Pegawai." *Penelitian Ipteks* 3(2): 176–85.
- Friolina, Delvia Gita, Sudarsih Sudarsih, Tatok Endhiarto, and Didik Pujo Musmedi. 2017. "Do Competence , Communication , And Commitment Affect The Civil Servants Performance ?" *International Journal of Scientific & Technology Research* 6(09): 211–15.
- Handoko, T. Hani. 2015. *Manajemen Personalia Dan Sumber Daya Manusia*. Yogyakarta: BPFE-Yogyakarta.
- Hasibuan, Erni Aprida, and Afrizal. 2019. "ANALISIS PENGARUH KOMPETENSI,

- LINGKUNGAN KERJA, DAN KOMPENSASI TERHADAP KEPUASAN KERJA DAN IMPLIKASINYA TERHADAP KINERJA APARATUR SIPIL NEGARA Erni.” *JEM: Jurnal Ekonomi dan Manajemen STIE Pertiba Pangkalpinang* 5(1): 22–41.
- Hasibuan, Malayu S.P. 2016. *Manajemen Sumber Daya Manusia. Edisi. Revisi*. Jakarta: Bumi Aksara.
- Herawati, and Mahfudnurnajamuddin. 2018. “Pengaruh Kompetensi, Disiplin Dan Iklim Organisasi Terhadap Kinerja Pegawai Pada Balai Besar Pelaksanaan Jalan Nasional vi Kementerian Pekerjaan Umum Makassar.” *PARADOKS Jurnal Ilmu Ekonom* 1. <https://databoks.katadata.co.id/datapublish/2022/12/06/jumlah-koperasi-di-indonesia-kembali-meningkat-semenjak-pandemi>. 2022. “No Title.”
- Hutajulu, Yossi Maria Marinta, Lelo Sintani, and Meitiana Meitiana. 2020. “Pengaruh Disiplin Dan Budaya Kerja Terhadap Kinerja ASN Melalui Motivasi Kerja Satpol PP Provinsi Kalimantan Tengah.” *Journal of Environment and Mangement* 2(2). <https://e-journal.upr.ac.id/index.php/jem/article/view/2658/2324>.
- Ilmi, Nailatul, Mochamad Arifianto, and Nurul Qomariah. 2023. “IMPROVING EMPLOYEE PERFORMANCE THROUGH PROVIDING ADDITIONAL EMPLOYEE INCOME AND WORK.” *International Journal of Management Science and Information Technology (IJMSIT)* 3(1).
- Ingsih, Kusni, Rini Laksmi Yanuardan, and Suhana Suhana. 2021. “The Role of Work Discipline, Work Motivation, and Organizational Commitment Through Job Satisfaction on Nursing Performance in Indonesia.” *Jurnal Aplikasi Manajemen* 19(4): 838–48. <https://jurnaljam.ub.ac.id/index.php/jam/article/view/2166/1695>.
- Iskandar, Sentot, and Enceng Juhana. 2014. “Pengaruh Kompetensi Dan Lingkungan Kerja Terhadap Kepuasan Kerja Serta Implikasinya Pada Kinerja Guru Di SDN Baros Mandiri 5 Kota Cimahi.” *Jurnal Ekonomi, Bisnis & Entrepreneurship* 8(2): 86–98. <http://jurnal.stiepas.ac.id/index.php/jebe/article/view/41>.
- Jufrizen, and Tiara Safani Sitorus. 2021. “Pengaruh Motivasi Kerja Dan Kepuasan Kerja Terhadap Kinerja Dengan Disiplin Kerja Sebagai Variabel Intervening.” In *SiNTESa CERED Seminar Nasional Teknologi Edukasi Dan Humaniora*, , 841–56.
- Kapahang, Jennifer Octora, Christoffel Kojo, and Yantje Uhing. 2014. “Pendidikan, Pengalaman Kerja Dan Kompetensi Pengaruhnya Terhadap Kinerja Karyawan Pada Pt. Pln (Persero) Wilayah Suluttenggo.” *Jurnal EMBA* 2(4): 503–13. <http://www.spectrumgroupe.fr/product/microsoft-teams/>.
- Liana, Yuyuk, and Rina Irawati. 2014. “Peran Motivasi, Disiplin Kerja Terhadap Komitmen Karyawan Dan Kinerja Karyawan Pada Perusahaan Air Minum Di Malang Raya.” *Jurnal Manajemen dan Akuntansi* 3(1): 17–34.
- Lopes, Eusebio da Costa. 2016. “Pengaruh Motivasi Terhadap Disiplin Kerja Dan Kinerja Pegawai Pada Direccao Geral Dos Servicos Corporativos Ministerio Das Obras Publicas Dili Timor-Leste.” *Jurnal Sains Manajemen & Bisnis Indonesia* 6(2): 158–69.
- Lumentut, Mauritz D.S, and Lucky O.H Dotulong. 2015. “Pengaruh Motivasi, Disiplin, Dan Lingkungan Kerja Terhadap Kepuasan Kerja Karyawan Pada PT. Bank SULUT Cabang Airmadidi.” *Jurnal EMBA, ISSN: 2303-1174* 3(1): 74–85.
- Makkira, Gunawan, and Abdul razak Munir. 2016. “Pengaruh Disiplin Kerja, Komitmen Organisasi Dan Lingkungan Kerja Terhadap Kinerja Karyawan Pada PT Trans Retail Indonesia (Carrefour) Cabang Panakkukang Makassar.” *Jurnal Mirai Management* 1(1): 211–27. <https://journal.stieamkop.ac.id/index.php/mirai/article/download/15/15>.
- Manese, Lemarchy ESterina, Adolfina Adolfina, and Mac DB Walangitan. 2020. “Pengaruh Budaya Organisasi, Kualitas SDM, Disiplin Terhadap Motivasi Dan Kinerja Karyawan Pada PT. PLN (Persero) Area Manado.” *Jurnal EMBA* 8(3): 353–62. <https://ejournal.unsrat.ac.id/index.php/emba/article/view/30086>.

- Mangkunegara, A.A. Prabu. 2018. *Manajemen Sumber Daya Manusia, Cetakan Kedua*. Bandung: PT Remaja Rosdakarya.
- Mangkunegara, A.A Anwar Prabu. 2017. 53 PT. Remaja Rosdakarya. Bandung *Manajemen Sumber Daya Manusia Perusahaan*. Bandung: Remaja Rosdakarya.
- Manik, Sudarmin, and Nova Syafrina. 2018. “Pengaruh Kompetensi Terhadap Kinerja Dosen Sekolah Tinggi Ilmu Ekonomi Riau.” *Jurnal Ilmiah Ekonomi Dan Bisnis* 15(1): 1–6.
- Mu’ah, Mu’ah et al. 2023. “The Role of HR Quality and Work Discipline in Improving the Motivation and Performance of District Court Employees.” *Budapest International Research and Critics Intitute Journal (BIRCI)* 6(3): 1378–88.
- Muhsin, and Nur Shinta; Arifa. 2018. “Pengaruh Disiplin Kerja, Kepemimpinan Dan Lingkungan Kerja Terhadap Kinerja Melalui Motivasi Kerja.” *Economic Education Analysis Journal* 7(1): 374–89.
<https://journal.unnes.ac.id/sju/index.php/eeaj/article/view/22888/10801>.
- Mulyani, Sitti Rizki, and Mona Agus Saputri. 2019. “Pengaruh Kompetensi Pegawai, Penempatan Kerja Dan Pengembangan Karir Terhadap Kinerja Pegawai.” *Psyche 165 Journal* 12(1): 51–63. <https://jpsy165.org/ojs/index.php/jpsy165/article/view/51/47>.
- Mustikawati, Endang, and Nurul Qomariah. 2020. “The Effect of Education , Training and Competency on Teacher Performance.” *International Journal of Business and Management Invention (IJBMI)* 9(10): 14–20.
- Nitisemito, Alex S. 2014. *Manajemen Personalia. Edisi Revisi*. Jakarta: Ghalia Indonesia.
- Novita, Melda, and Prima Yulianti. 2020. “Pengaruh Kompetensi Sosial Dan Kompetensi Profesional Terhadap Penilaian Kinerja Dosen Universitas Dharma Andalas Padang.” *Jurnal Ekonomi dan Bisnis Dharma Andalas* 22(2): 241–54.
<http://www.jurnal.unidha.ac.id/index.php/JEBD/article/view/137/91>.
- Nuriyah, Sinta, Nurul Qomariah, and Trias Setyowati. 2022. “PENGARUH PENGEMBANGAN KARIR, LINGKUNGAN KERJA DAN DISIPLIN KERJA TERHADAP KINERJA PEGAWAI PUSKESMAS PADANG.” *JIMEA / Jurnal Ilmiah MEA (Manajemen , Ekonomi , dan Akuntansi)* 6(1): 14–31.
<http://journal.stiemb.ac.id/index.php/mea/article/view/1768>.
- Nursaid, Nursaid et al. 2020. “Improvement of Job Satisfaction Based on Work Motivation , Work Environment , Competence and Compensation for Hospital Employees : Peningkatan Kepuasan Kerja Berdasarkan Motivasi Kerja , Lingkungan Kerja , Kompetensi Dan Kompensasi Untuk Karyawan Rumah Sa.” *Indonesian Journal of Law and Economics Review Vol 7 (2020)*: 7(40): 1–11.
- Parashakti, Ryani Dhyan, Mochammad Fahlevi, and Muhamad Ekhsan. 2020. “The Influence of Work Environment and Competence on Motivation and Its Impact on Employee Performance in Health Sector.” *Advances in Economics, Business and Management Research* 135: 259–67.
- Permanasari, Resi, Rina Moestika Setyaningrum, and Siti Sundari. 2014. “Model Hubungan Kompetensi, Profesionalisme Dan Kinerja Dosen Relationship Model Between Competence , Professionalism and Performance Teaching.” *Jurnal Bisnis, Manajemen & Perbankan* 1(2): 157–74. <http://journal.feb.unmul.ac.id/index.php/KINERJA>.
- Pinca, Estrellita C. 2015. “The Mobile Teachers Profile Competencies Performance And Problems In The Department Of Education Division Of Northern Samar Philippines.” *International Journal of Scientific & Technology Research* 4(8): 45–50.
- Pioh, Nancy L, and Hendra N Tawas. 2016. “Pengaruh Kompensasi Dan Lingkungan Kerja Terhadap Kepuasan Kerja Dan Kinerja Pegawai (Studi Pada PNS Di Kantor Kecamatan Sonder Kabupaten Minahasa).” *Jurnal EMBA* 4(2): 838–48.
- Prakoso, Rayka Dantyo, Endang Siti Astuti, and Ika Ruhana. 2014. “PENGARUH

- LINGKUNGAN KERJA TERHADAP MOTIVASI KERJA DAN KINERJA KARYAWAN (Studi Pada Karyawan PT. AXA Financial Indonesia Cabang Malang).” *Jurnal Administrasi Bisnis (JAB)* 14(2): 1–10.
<http://administrasibisnis.studentjournal.ub.ac.id/index.php/jab/article/view/596/795>.
- Pribadi, Teddi. 2018. “PENGARUH LINGKUNGAN KERJA DAN MOTIVASI TERHADAP KEPUASAN KERJA KARYAWAN PT MATAHARI DEPARTEMEN STORE CABANG THAMRIN PLAZA MEDAN.” *Majalah Ilmiah Politeknik Mandiri Bina Prestasi* (1): 28–37.
- Priyono, Bayu Hendro, Nurul Qomariah, and Pawestri Winahyu. 2018. “Pengaruh Gaya Kepemimpinan, Motivasi Guru Dan Lingkungan Kerja Fisik Terhadap Kinerja Guru Sman 1 Tanggul Jember.” *Jurnal Manajemen Dan Bisnis Indonesia* 4(2): 144.
- Pujiarti. 2019. “Pengaruh Kompetensi Dan Kompensasi Terhadap Kinerja Karyawan Dengan Kepuasan Kerja Sebagai Variabel Intervening Pada PT . Pilar Guna Usahatama.” *PRIMANOMICS : JURNAL EKONOMI DAN BISNIS - 1*: 1–14.
- Putra, I Wayan Indra, I Wayan Suwendra, and I Wayan Bagia. 2016. “PENGARUH TINGKAT PENDIDIKAN DAN DISIPLIN KERJA TERHADAP KINERJA KARYAWAN I.” *e-Journal Bisma Universitas Pendidikan Ganesha* 4(1).
- Qomariah, Nurul. 2014. *Ekonomi Skala Kecil Menengah Dan Koperasi*. Jember: Cahaya Ilmu.
<https://scholar.google.com/scholar?cluster=112258519452519018&hl=en&oi=scholar>.
- . 2020. *Manajemen Sumber Daya Manusia: Teori, Aplikasi Dan Studi Empiris*. 1st ed. Jember: Pustaka Abadi.
https://www.researchgate.net/publication/356291163_MANAJEMEN_SUMBER_DAYA_MANUSIA_Teori_Aplikasi_dan_Studi_Empiris.
- . 2020. 13 International Journal of Engineering Research and Technology *The Impact of Leadership Style, Work Environment and Job Satisfaction on Employee Performance*. <http://www.irphouse.com>.
- Qomariah, Nurul, Nursaid, Dian Eka Mardana, and Pawestri Winahyu. 2021. “Impact of Leadership Style, Motivation and Work Environment on Employee Performance.” *CELSciTech-2021* 5: 15–23.
<https://ejournal.umri.ac.id/index.php/PCST/article/view/3260>.
- Qomariah, Nurul, Mochamad Rochmadoni, Aviciena iqbal Rush, and Anita Eka Navalina. 2023. “The Impact of Leadership , Employee Competence and Organizational Work Culture on Employee Performance At.” *Budapest INternational Research and Critics Intitute Journal (BIRCI)* 6(2): 1143–57.
- Raffie, Desi Saputro, Nasir Azis, and Sofyan Idris. 2018. “Pengaruh Kompetisi, Gaya Kepemimpinan, Budaya Kerja Dan Lingkungan Kerja Terhadap Kepuasan Kerja Pegawai Dan Dampaknya Terhadap Kinerja Pegawai Kantor Kementerian Agama Kabupaten Aceh Barat.” *Jurnal Magister Manajemen Fakultas Ekonomi dan Bisnis Unsyiah, ISSN : 2302-0199* 2(1): 36–45.
- Rahim, Abdul, Saiyid Syech, and Muhammad Zahari. 2017. “PENGARUH LINGKUNGAN KERJA DAN KOMPETENSI TERHADAP MOTIVASI KERJA SERTA DAMPAKNYA TERHADAP KINERJA PEGAWAI PADA DINAS PENDIDIKAN KABUPATEN TANJUNG JABUNG TIMUR.” *Jurnal Manajemen dan Sains* 2(2): 133–49. <http://jmas.unbari.ac.id/index.php/jmas/article/view/25/29>.
- Rande, Dina. 2016. “Pengaruh Kompetensi Terhadap Kinerja Pegawai Pada Dinas Perhubungan, Komunikasi Dan Informatika Kabupaten Mamuju Utara.” *e Jurnal Katalogis* 4: 101–9.
- Ratnasari, Ni Putu Intan, and AA Sagung Kartika Dewi. 2014. “Pengaruh Motivasi,

- Lingkungan Kerja Fisik Dan Kepemimpinan Terhadap Kepuasan Kerja Karyawan.” *E-Jurnal Manajemen Universitas Udayana* 3(7): 246091.
- Rosalina, Maudy, and Lela Nurlaela Wati. 2020. “Pengaruh Gaya Kepemimpinan Terhadap Disiplin Kerja Dan Dampaknya Terhadap Kinerja Karyawan.” *Jurnal Ekobis : Ekonomi Bisnis & Manajemen* 10(1): 18–32.
<http://ejournal.stiemj.ac.id/index.php/ekobis/article/view/26/73>.
- Rusmayanti, Putu Ayu, Ni Nyoman Putu Martini, and Nurul Qomariah. 2022. “The Effect of Competence and Job Satisfaction on Organizational Citizenship Behavior and Employee Performance.” *International Journal of Business and Management Invention (IJBMI)* 11(1): 21–29.
- Safitri, Erma. 2013. “Pengaruh Pelatihan Dan Disiplin Kerja Kinerja Karyawan.” *Jurnal Ilmiah Manajemen* /1(4):1044–54.
<https://ejournal.unesa.ac.id/index.php/jim/article/view/6262>.
- Sanjaya, Fanlia Adiprimadana. 2021. “Dampak Budaya Kerja Dan Disiplin Kerja Terhadap Kinerja Karyawan (Studi Kasus : PT Kaltrabu Indah Tour & Travel Banjarmasin).” *Jurnal Ilmiah Ekonomi Binis* 7(1): 070–082.
- Saputri, Yeni Widya, Nurul Qomariah, and Toni Herlambang. 2020. “Effect Of Work Compensation , Supervision And Discipline On Work Performance.” *INTERNATIONAL JOURNAL OF SCIENTIFIC & TECHNOLOGY RESEARCH* 9(01).
- Sedarmayanti. 2017a. *Pernecanaan Dan Pengembangan SDM Untuk Meningkatkan Kompetensi, Kinerja, Dan Produktivitas Kerja*. Bandung: PT. Refika Aditama.
- . 2017b. *Sumber Daya Manusia Dan Produktivitas Kerja*. Bandung: CV Mandar Maju.
- Setiawan, Yudi, and Nurul Qomariah. 2022. “The Role of Competence , Leadership , Work Environment and Motivation in Improving Employee Performance.” *International Journal of Humanities and Social Science Invention (IJHSSI)* 11(2): 47–58.
- Setiawati, Tati. 2017. “Pengaruh Kompetensi Kerja Terhadap Kinerja Dosen.” *Media Pendidikan, Gizi, dan Kuliner* 1(1): 1–5.
- Sholehatusya’diah. 2017. “Pengaruh Kompetensi Kerja Terhadap Kinerja Karyawan Di Kantor PT. Kitadin Tenggara Seberang.” *eJournal Administrasi Negara* 5(2): 5789–5802.
- Simbolon, Sahat. 2017. “Pengaruh Kepemimpinan Visioner , Motivasi , Dan Kompetensi Terhadap Budaya Kerja Dan Komitmen Serta Implikasinya Pada Kinerja Dosen.” *Kontigensi Volume 5, No.2 November 2017, Hal. 87 - 97 ISSN 2088-4877* 5(2): 87–97.
- Sitinjak, Lulu Novena. 2018. “Pengaruh Lingkungan Kerja Terhadap Kepuasan Kerja Karyawan (Studi Pada Karyawan PT. Mitra Pinasthika Mustika Rent Tangerang Selatan).” *Jurnal Administrasi Bisnis (JAB)* 60(2): 162–68.
- Sugiono, Edi, and Dewi Sintia Vitaloka. 2019. “Analysis the Effect of Work Stress, Work Discipline and Turnover Intention on Employees Performance Mediated by Job Satisfaction at Pt. Epson Indonesia, Jakarta.” *International Journal of Scientific and Technology Research* 8(12): 2574–80.
- Sugiyatmi, Maria Magdalena Minarsih, and Edward Gagah. 2016. “Pengaruh Motivasi, Gaya Kepemimpin Dan Lingkungan Kerja Terhadap Disiplin Kerja Serta Dampaknya Terhadap Kinerja Karyawan Di Pt Bina San Prima.” *Journal Of Management* 2(2).
<http://jurnal.unpand.ac.id/index.php/MS/article/view/534/520>.
- Sugiyono. 2016. “Metode Penelitian Kualitatif, Kuantitatif Dan R& D.” *Alfabetha Bandung*.
———. 2017. *Metode Penelitian Kuantitatif, Kualitatif, Dan R&D*. Bandung: Alfabeta.
- Sukowidodo, Tri, Abadi Sanosra, Arik Susbiyani, and Nurul Qomariah. 2022. “Efforts to Improve Employee Performance Through Training , Competence , Work Environment and Organizational Commitment at Public Health Centers in Banyuwangi.” *Quest*
-

Journals Journal of Research in Business and Management 10(7): 109–18.

- Sumowo, Seno. 2017. “ANALISIS DISIPLIN KERJA DAN MOTIVASI KERJA TERHADAP PRESTASI KERJA KARYAWAN PADA LAVA – LAVA HOSTEL DAN RESTO PROBOLINGGO Seno Sumowo Fakultas Ekonomi Universitas Muhammadiyah Jember Email : Senosumowo@unmuhjember.Ac.Id PENDAHULUAN Di Dalam Kehidupan Seha.” *Jurnal Penelitian IPTEKS* (2): 49–60.
- Suwondo, Diah Indriani, and Eddy Madiono Sutanto. 2015. “HUBUNGAN LINGKUNGAN KERJA, DISIPLIN KERJA, DAN KINERJA KARYAWAN.” *Jurnal Manajemen dan Kewirausahaan* 17(2): 41–59.
<http://puslit2.petra.ac.id/ejournal/index.php/man/article/view/16793>.
- Sya’roni, Toni Herlambang, and Dwi Cahyono. 2018. “DAMPAK MOTIVASI, DISIPLIN KERJA DAN KEPEMIMPINAN KEPALA SEKOLAH TERHADAP KINERJA GURU.” *Jurnal Sains Manajemen & Bisnis Indonesia* 8(2): 131–47.
- Syahputra, F. 2021. “Pengaruh Disiplin Kerja, Etika Dan Konflik Kerja Terhadap Kinerja Karyawan Pada PT. Pasti Jaya Elektrik Medan.” *Jurnal Ilmiah Mahasiswa Ekonomi dan Bisnis [JIMEIS]* 1(4): 1–13. <http://repository.umsu.ac.id/handle/123456789/15898>.
- Tilaar, Natalia R, Greis M Sendow, and Rotinsulu Jopie Jorie. 2017. “Pengaruh Kualitas Kehidupan Kerja, Disiplin Kerja Dan Kompensasi Terhadap Produktivitas Kerja Pegawai Pada Kantor Dinas Lingkungan Hidup Provinsi Sulawesi Utara.” *Jurnal EMBA* 5(2): 2070–78.
- Titisari, Purnamie, Arnis Budi Susanto, and Yulita Permatasari. 2021. “The Role of Internal Communication, Work Discipline, And Employee Loyalty on Employee Performance.” *Quality - Access to Success* 22(184): 166–70.
- Utomo, Artiantyo Wirjo, Nurul Qomariah, and Nursaid. 2019. “The Impacts of Work Motivation , Work Environment , and Competence on Performance of Administration Staff of Dr . Soebandi Hospital Jember East Java Indonesia.” *International Journal of Business and Management Invention (IJBMI)* 8(09): 46–52.
[http://www.ijbmi.org/papers/Vol\(8\)9/Series-2/G0809024652.pdf](http://www.ijbmi.org/papers/Vol(8)9/Series-2/G0809024652.pdf).
- Wahyudi, Arif, Nurul Qomariah, and Abadi Sanosra. 2022. “ANALYSIS OF THE EFFECT OF TEACHER COMPETENCY AND WORK ENVIRONMENT ON TEACHER PERFORMANCE WITH MOTIVATION AS INTERVENING VARIABLE AT PRIVATE VOCATIONAL SCHOOL IN BONDOWOSO DISTRICT.” *International Journal of Management Science and Information Technology (IJMSIT)* 2(1): 19–27.
- Wasiman. 2020. “Effect of Organizational Culture, Rewards, Competence, and Organizational Citizenship Behavior.” *International Journal of Scientific and Technology Research* 9(2): 6329–33.
- Wibowo. 2012. *Manajemen Kinerja (Edisi Ke 3)*. Jakarta: Rajawali Pers.
- Wibowo, Mukti, Mochammad Al Musadieg, and Gunawan Eko Nurtjahjono. 2014. “Pengaruh Lingkungan Kerja Terhadap Kepuasan Kerja Karyawan.” *Jurnal Administrasi Bisnis (JAB)* 16(1): 1.